

 MV. TOYO DREAM

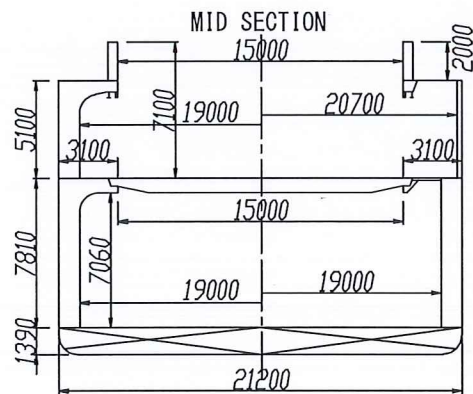
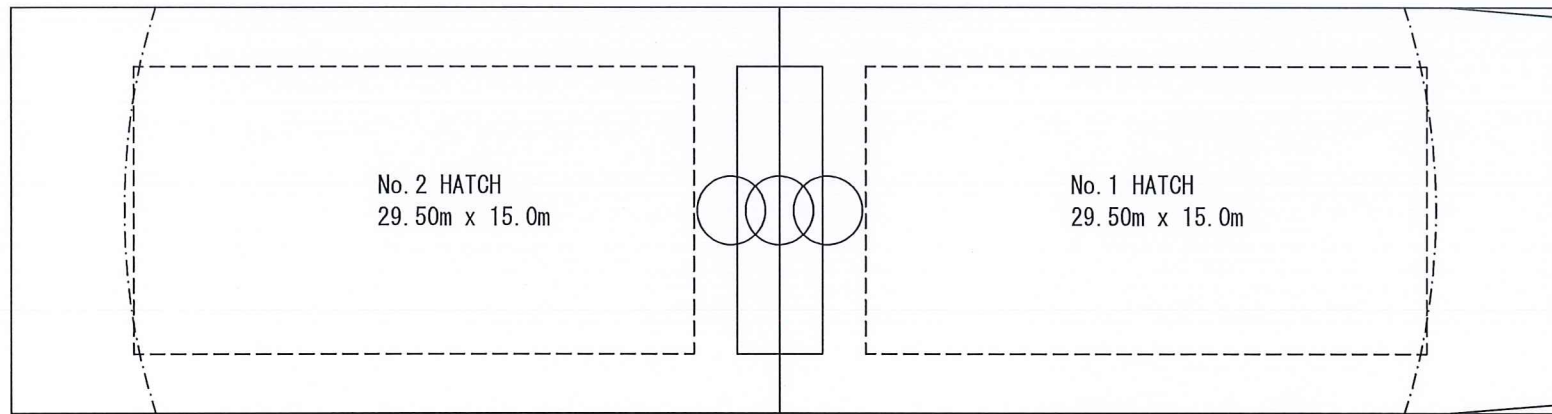
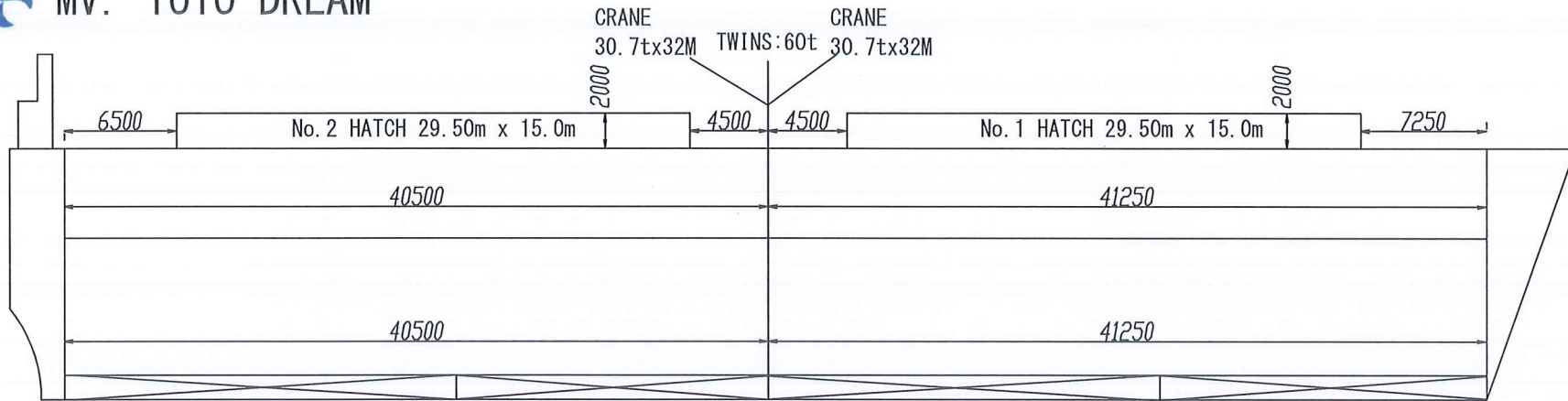

MEGAH ENAM

PRINCIPAL PARTICULAR	
LOA	119.99M
Lpp	111.50M
B(mid)	21.20M
D(mid)UPP	14.30M
DRAFT	8.80M
G/T	9,593T
N/T	3,748T
D/W	12,926T
G. CAPA	20,842.70M3
B. CAPA	19,844.60M3

 MV. TOYO DREAM

SECOND DECK

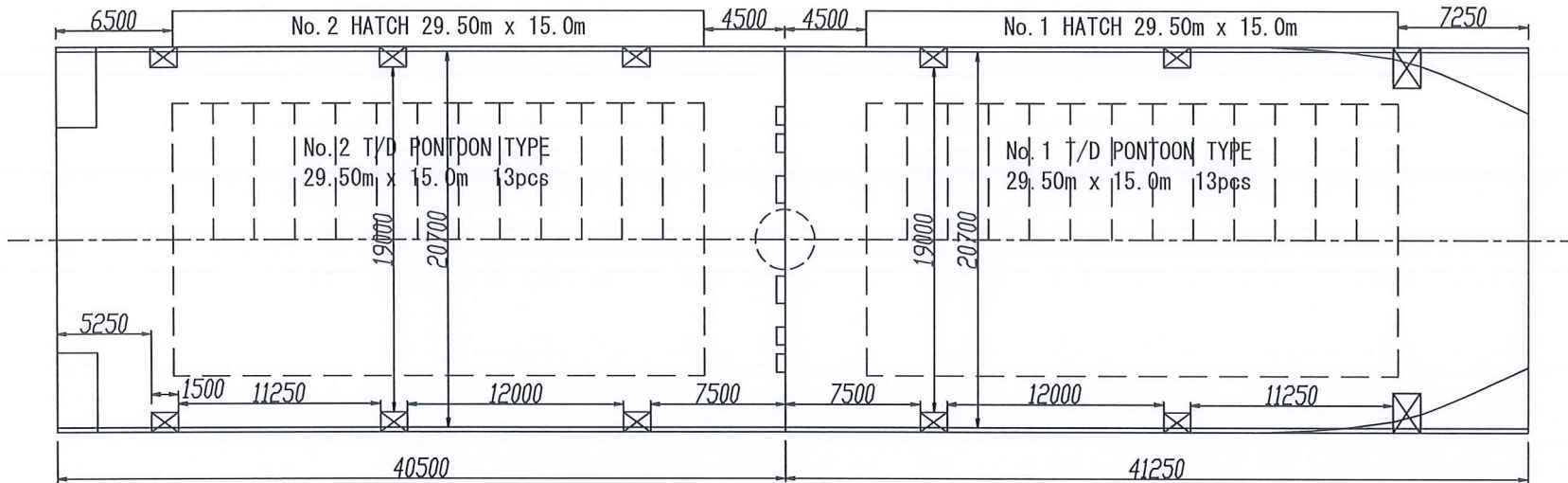

BOTTOM

